

Wat willen we doen?

Sloop 9 woningen

Van Rechterenstraat 1 t/m 9

Van Heemstraweg 1 t/m 7

Nieuw te bouwen

48 sociale huurappartementen

Oppervlakte appartementen

ca. 50 m² en 65 m²

**34 parkeerplaatsen
op nieuw parkeerterrein**

Groene omgeving

Locatien in Wassenaar



Voor en na situatie

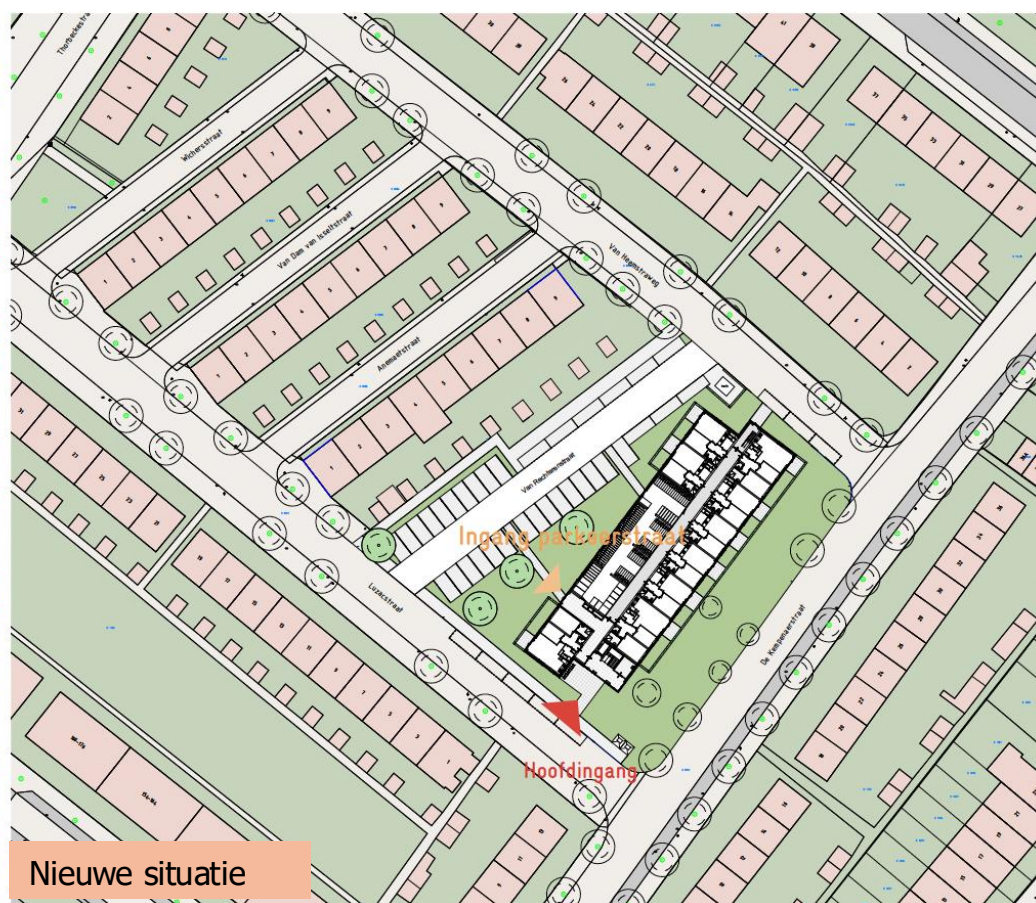

Uitgangspunten Stedenbouw & massa

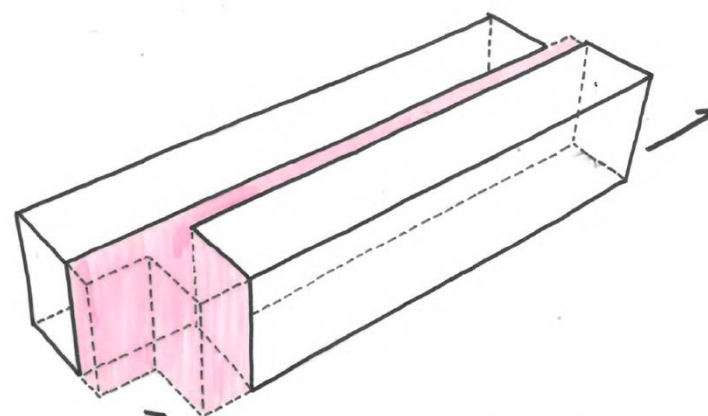
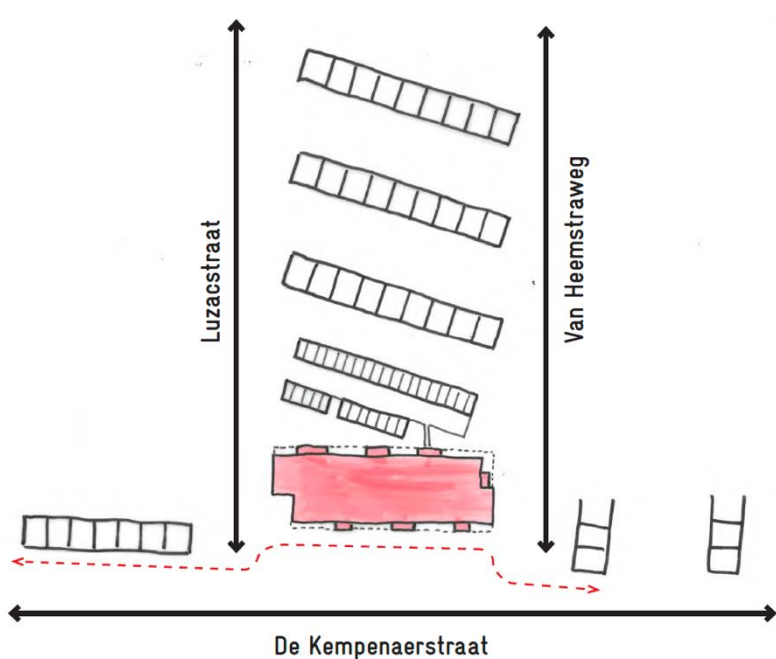

duidelijke entreepartij door het schuiven van de twee hoofdvolumes.

Uitgangspunten Stedenbouw & massa

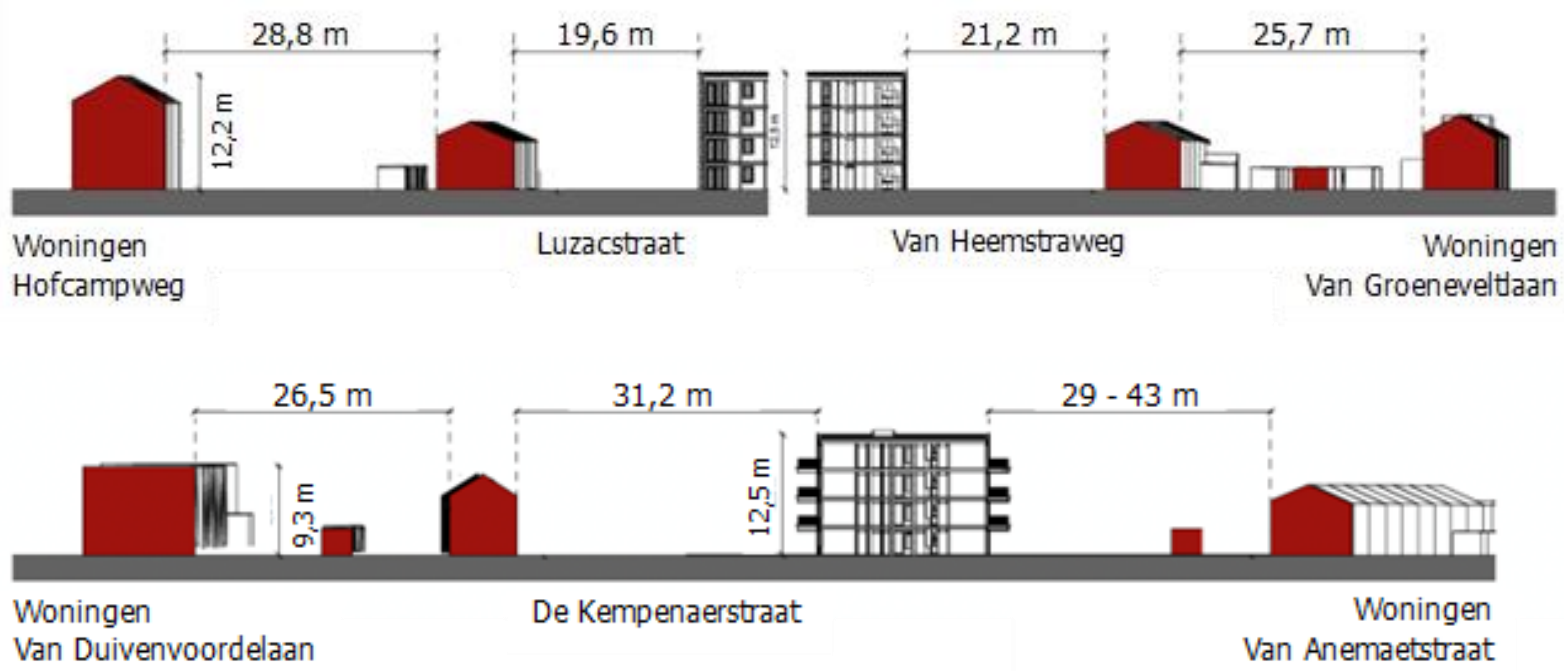

Zonnestudie

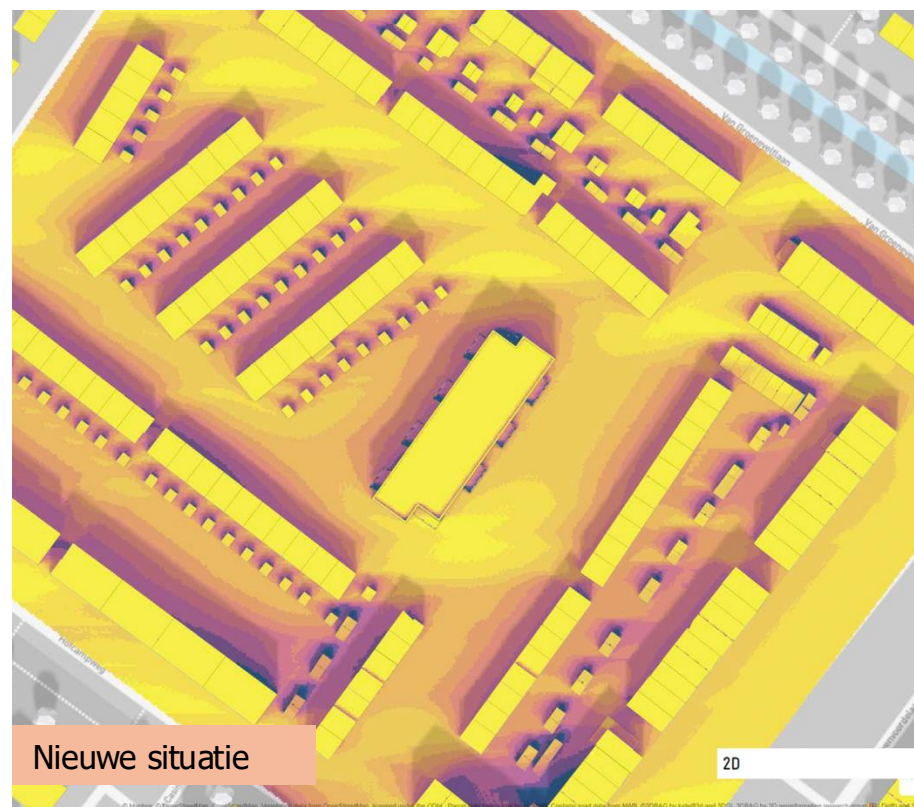
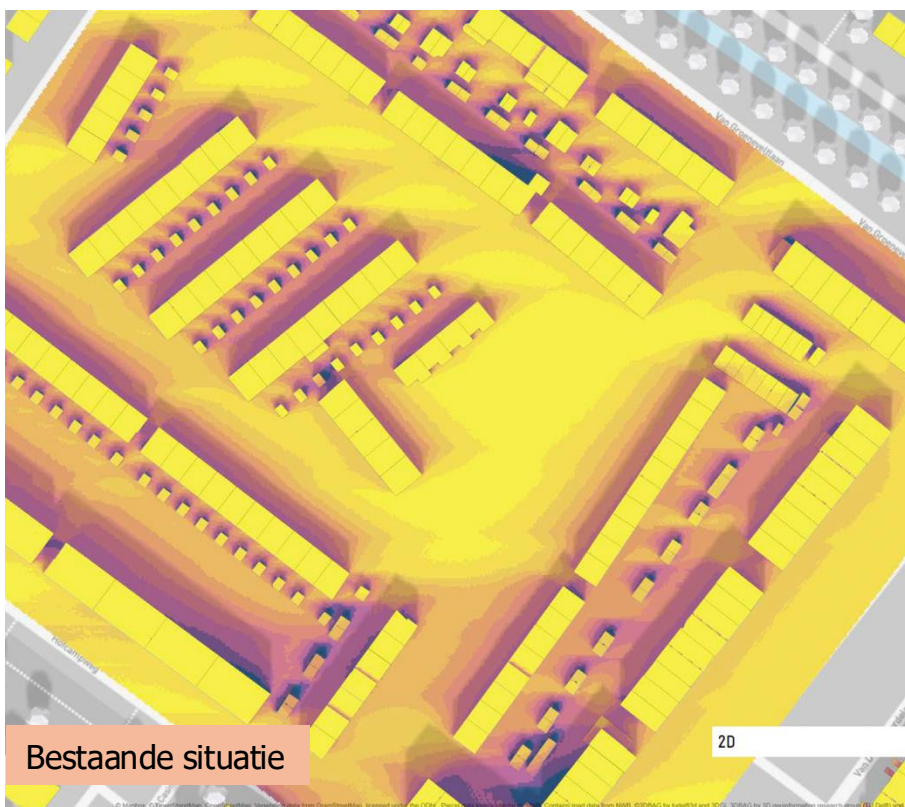

Programma

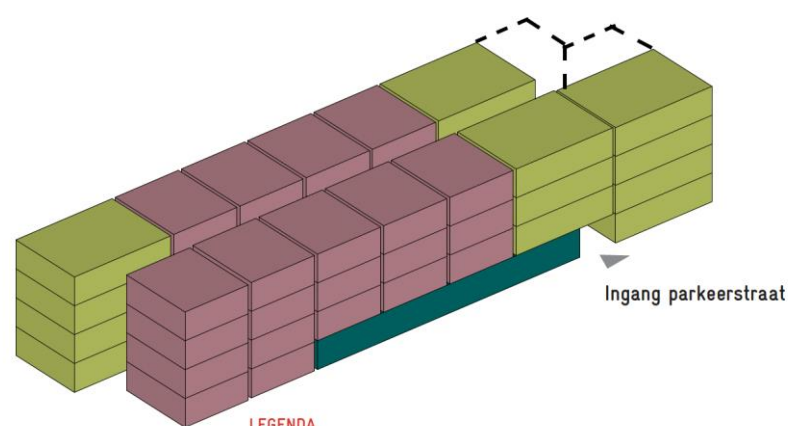
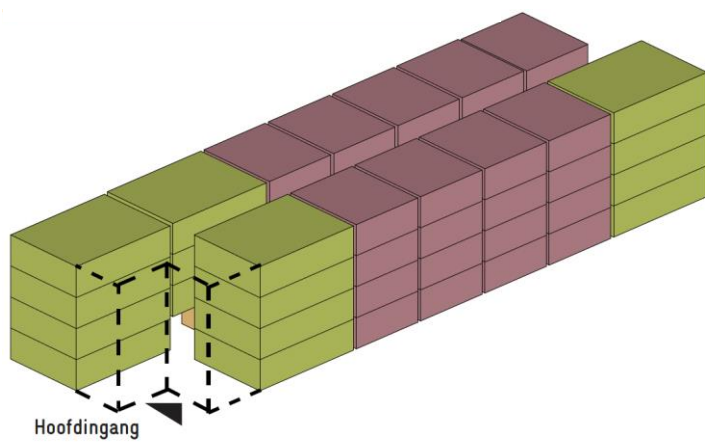

LEGENDA

- 2 kamer appartement
- 2 kamer appartement
- gemeenschappelijke berging

Impressies



Gevel vanaf De Kempenaerstraat



Gevel vanaf Luzacstraat, hoofdingang



Gevel vanaf Van Heemstraweg



Gevel vanaf zijde parkeerplaats

Belangrijkste vervolgstappen

Verder uitwerken ontwerp

Ruimtelijke ordeningsprocedures

- Vergunningsaanvraag
Buitenplanse omgevingsplanactiviteit
*(ontwerp past namelijk niet
in het omgevingsplan)*

Aanvraag Omgevingsvergunning voor bouwen

Verwachte start sloop en nieuwbouw
Vanaf tweede helft 2026